

Pro-Alumarail

Railing Installation Instructions Series 100 & Series 375

Recommended Materials

- | | |
|---------------------|---|
| 1. Pencil | 10. Impact driver |
| 2. Tape measure | 11. Electric miter saw with a 10" carbide blade specifically for cutting aluminum |
| 3. Level | 12. Drill bits = 9/64", 11/64", 1/4", 3/8" |
| 4. Square | 13. Screw driver bits = #2 Phillips & a T-30 Allen (socket) head bit |
| 5. Speed square | 14. Screwdriver bit holder |
| 6. String line | |
| 7. Dead blow hammer | |
| 8. Rubber mallet | |
| 9. Drill | |

1 Rail Connecting Blocks (RCB)

1. Drill 11/64" pilot holes or use #16 drill along index lines.
2. Anchor block into post with #10 x 1 1/2 stainless steel screws.
3. RCB guide available upon request. If needed use clamp to hold RCB guide in place.

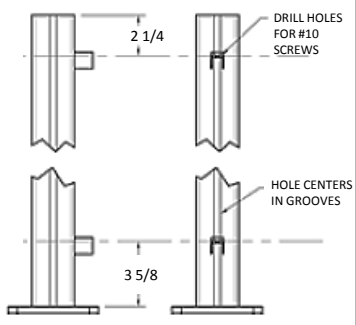

2 Post Layout

Maximum spacing between posts
 6' – with picket infill
 5' – with cable infill (with intermediate picket)
 5' – with glass infill

1. Intermediate posts are spaced evenly between end and corner posts. 135° corner posts are available.
2. Anchor posts with 3/8" stainless steel lag screws (lag screws not included). Screws must anchor into 4" of solid wood.
3. When installing 3/8" lag screw into baseplate, insert through 3/8" s-s washer, for nylon cap to snap over bolt head.



3 Top & Bottom Rail Attachment

Note: Install posts before cutting top and bottom rails

1. Measure inside to inside and cut rails to fit in between posts.
2. Attach rails to the rail connecting blocks using two #10 x 1/2" self drilling hex screws, using bottom v-groove as a screw guide.
3. Install bottom rail FIRST insuring that the ridged channel is facing upward.
4. Install top rail SECOND.

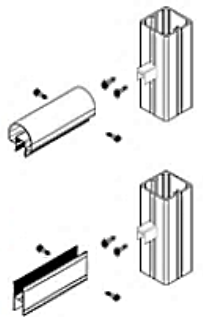

4 Measuring & Installing Picket or Glass Vinyl

1. Cut the top vinyl for the glass 3" shorter than the top rail for the rail connecting blocks.
2. Install top vinyl and bottom vinyl.

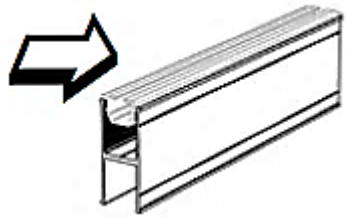

5 Pickets & Spacers

1. Insert Picket Vinyl into Vinyl channel in both bottom and top rails.
2. Picket spacers are used to evenly space the pickets. For proper balance between posts, make any necessary length adjustments to the first and last picket spacers. If necessary, use a rubber mallet to snap spacers into place.
3. Install pickets by snapping the two adjusted length picket spacers flush with the post on the top and bottom rails.
4. Slide one end of a picket into the bottom rail and swing the other end into the top rail channel. Push the picket flush and snap on two spacers.
5. It is necessary to install the last three pickets before the spacers. Shift the pickets around to allow spacer installation, the last two spacers installed will be the other two custom length spacers.

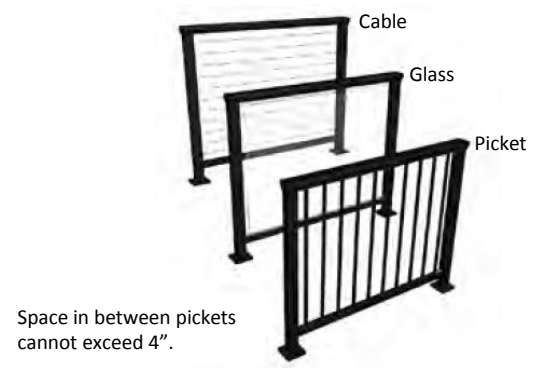

6 Measuring Glass

- (A) Glass Width = Measure from the inside of each post. Then deduct 3" total from your measurement. This will allow for 1 1/2" between posts and the glass. This is necessary for wind to pass through your system.
- (B) Glass Height = Measure from the inside of the top rail to the inside of the bottom rail. Then add 3/4" to your measurement. This addition will allow the glass to sit in the glass vinyl.

WIDTH
 Actual Measurement -3"

HEIGHT
 Actual Measurement +3/4"

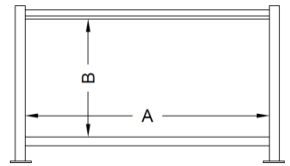

7 Installing Glass

1. Wet the flexible surface of the top and bottom vinyl.
2. Center the glass in the opening.
3. Insert the glass into the top vinyl.
4. Move the bottom edge of the glass over the bottom rail and lower into bottom vinyl.

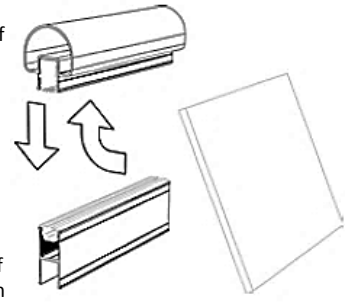

8 Install Post Cap

1. Put a bead of silicone adhesive on the inside perimeter of the post cap.
2. Insert cap onto post.

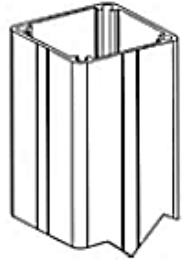
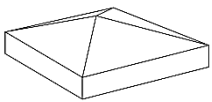

9 Intermediate Bottom Support

1. Drill a 5/16" hole in the web of the bottom rail.
2. Insert the intermediate bottom rail support into the bottom channel of the bottom rail.
3. Secure lag screw through the drilled 5/16" hole and center of the intermediate bottom support.



10 Stair Application

1. Vertical knuckles may be used at stair railing instead of mitering top and bottom rails.
2. Mount posts at top and bottom of rail run.
3. Position the post side of the knuckles at the top and bottom posts.
4. Cut and install the top rail.
5. If run is over 6' then intermediate posts are required. Measure and cut intermediate posts.
6. Install intermediate post fittings and bottom rail knuckles.
7. Install bottom rail. Measure, cut and attach bottom rails to knuckles and posts.
8. Ensure top rail has a minimum height of 34".

OR

Purchase RCB Extrusion.

12" RCB and cut to length for fastening rails cut to match stair angle.

Fascia Mount Diagram

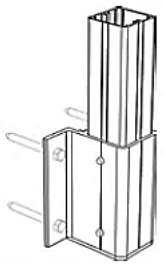

Stairway Rail

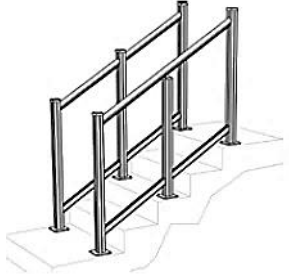

Picket Infill

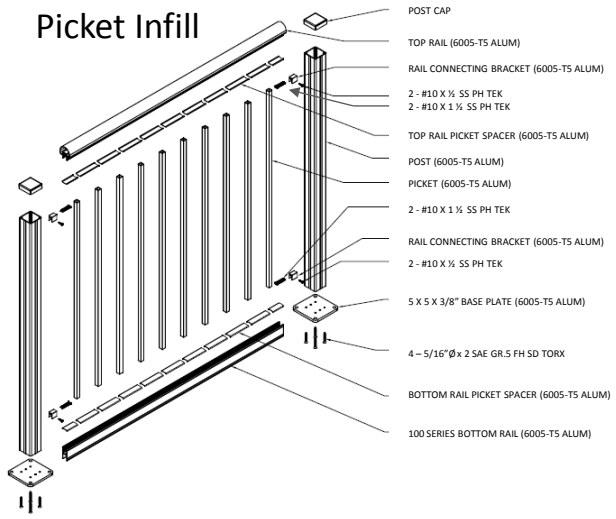

Glass Infill

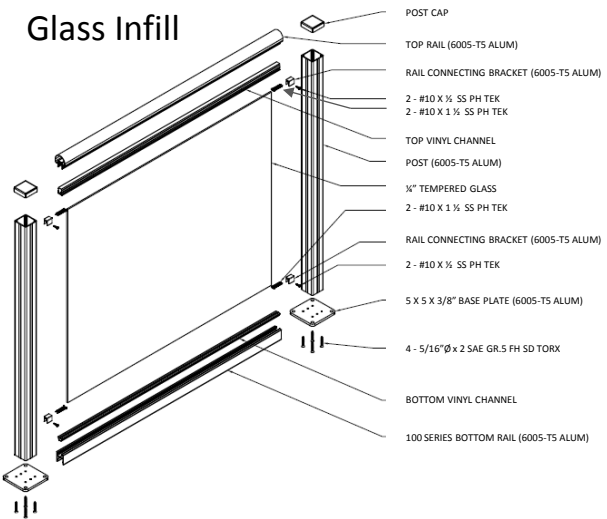

Cable Infill

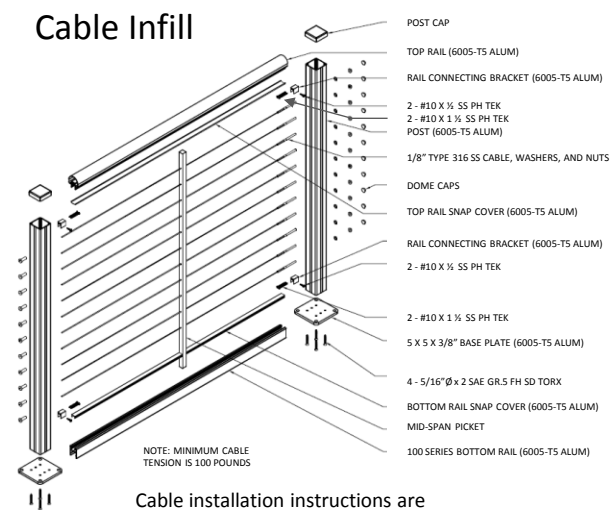

Cable installation instructions are included with the cable materials.